

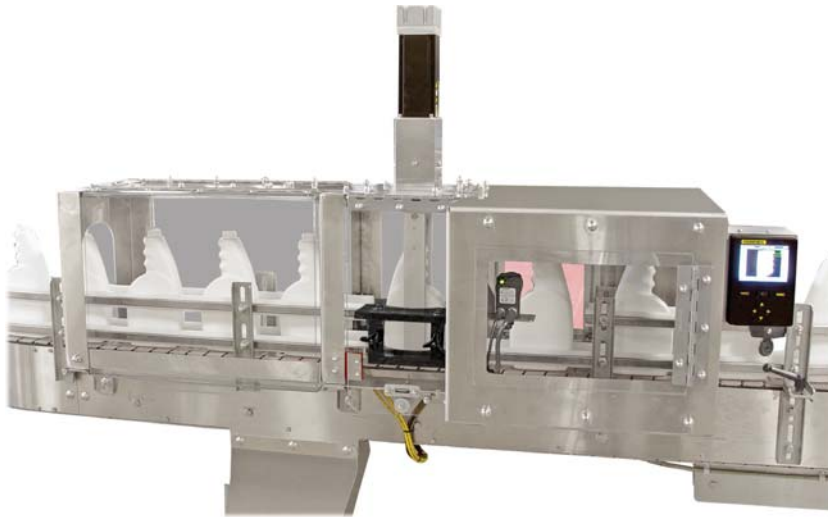

Bottle Orienter

NECO-ORIENTER 180

Orients non-round bottles into one direction.



Standalone
NECO-ORIENTER 180



NECO-ORIENTER 180
Integrated with
NECOSORT-S3-72
Plastic Bottle Unscrambler

Nalbach Engineering's Inline "0/180" degree orienter quickly, simply and inexpensively orients bottles into a common direction.

The NECO-ORIENTER Inline "0/180" degree bottle orienter is a servo driven system designed to turn non-round bottles into a common direction. Bottles are accepted from a single lane source and, based upon a Vision sensor's output allowed to pass if they are properly oriented, or spun 180 degrees if they are not properly oriented.

Benefits

- Fast. Runs speeds to 250 bpm.
- Simple. The servo motor is the only moving component in the system.
- Inexpensive. Simplicity means lower cost, lower maintenance and higher reliability.
- Easy Access. Hinged top provides easy access to all components and conveyor area.
- Servo Driven. Direct coupled servo drive design reduces part count while providing speed and accuracy.
- Vision system detects the smallest details for fast, easy, and accurate system setup.
- LEXAN enclosure provides complete visibility of the system's operation.
- Small and compact for easy integration. Easily fits into existing layouts without requiring a large section of dedicated conveyor.
- Fast changeovers. Easy change "turning forks" and bottle guides quickly and accurately change from one bottle format to another.

About Nalbach Engineering Company

Founded in 1945, our Company has earned its dominant reputation for quality and performance in the design and manufacture of a complete line of plastic bottle unscramblers and powder filling equipment. In addition, we offer aerosol fillers, turnkey packaging lines, and system integration services. A member of PMMI since 1958, Nalbach Engineering has developed equipment for a widely diverse client roster of Blue Chip companies and has installed systems in 45 countries around the globe.



NECO-ORIENTER 180 How it Works

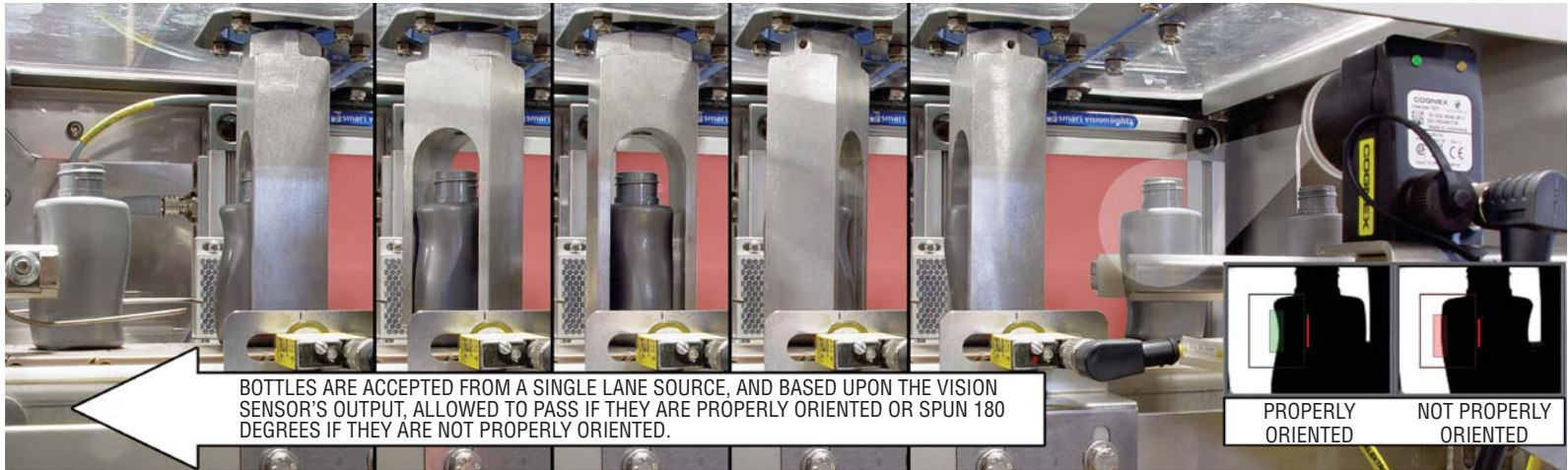

DIMENSIONS MAY CHANGE DEPENDING ON RANGE OF BOTTLE FORMATS TO BE RUN.

Standalone
NECO-ORIENTER 180

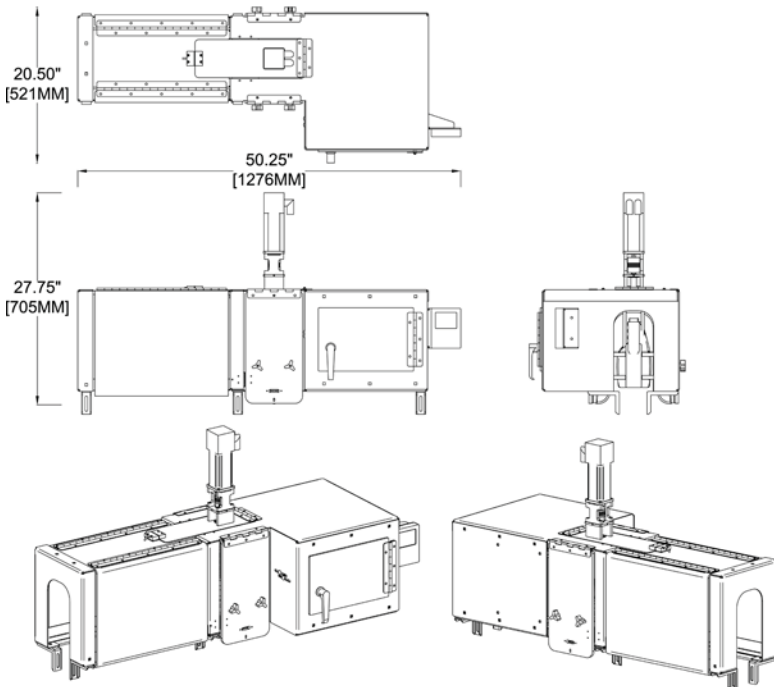

NECO-ORIENTER 180
Integrated with
Bottle Unscrambler

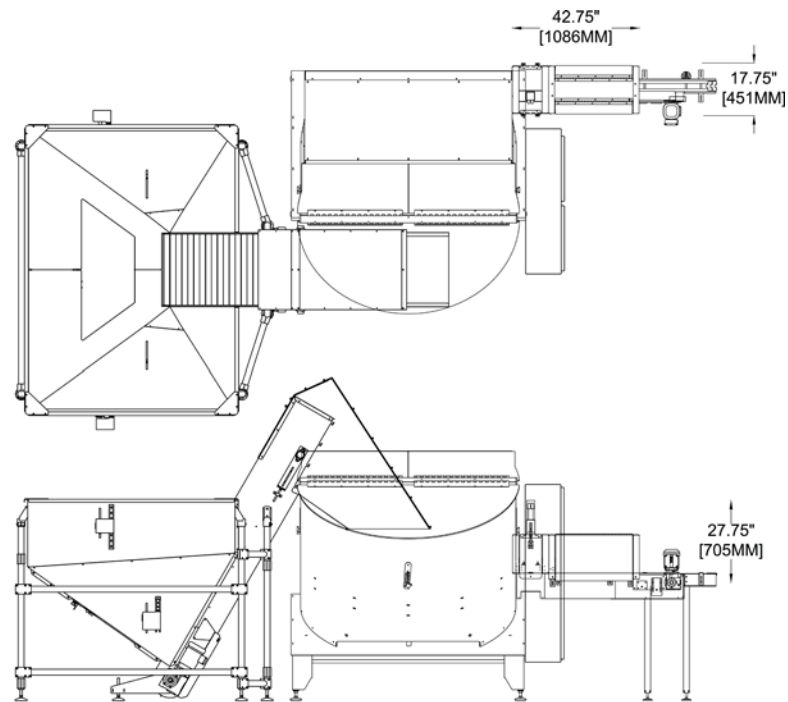

Dimensions Subject to Change Without Notice

